



# HOW 2 DIAGRAM

**Engine type:** all 4-stroke Diesel engine makes  
**Examples:** any 4-stroke Diesel fuel-injection engine  
**Product(s) for application:** Sea Foam Motor Treatment  
**Part number(s):** SF16 (pint), SF128 (gallon)



## ENGINE CYLINDER CUTAWAY – DIESEL FUEL INJECTION

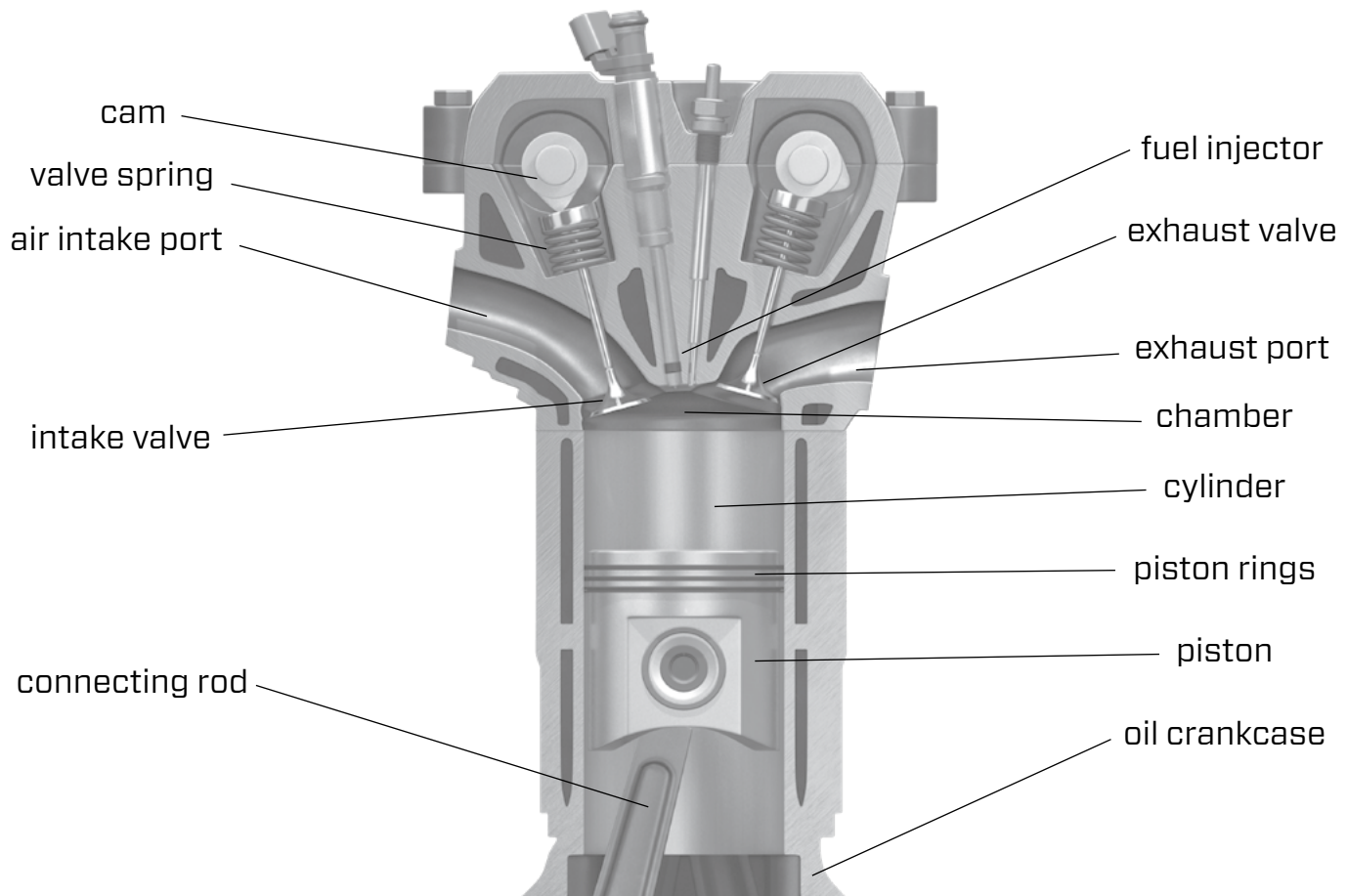

**BEFORE A COSTLY FUEL INJECTOR REPAIR:** When added to diesel fuel, Sea Foam Motor Treatment works to clean diesel fuel injectors and combustion chambers, lubricate upper cylinders, and dissolve harmful petroleum deposits throughout the fuel system. Cleaning fuel injectors helps to restore injector spray patterns, recover lost fuel volume and reclaim lost engine power.



### Treatments and recommendations for 4-stroke Diesel fuel injection systems:

- Use Sea Foam Motor Treatment in fuel to clean and lubricate fuel injectors, upper cylinders and chambers.
  - ✓ Add a maintenance dosage of Sea Foam Motor Treatment to diesel fuel every 2 to 3 months
  - ✓ Apply fuel filter cleaning method at least 1 or 2 times per year and whenever a primary fuel filter is replaced